

Standard configuration

Optional

Continuously variable transmission system	Backward buzzer	Cab	Protection net of overhead guard
Electro-hydraulic direction changing	Backrest	Air conditioner(certain type)	Reversing voice speaker
Air filter pressure alarm	Driver's tool	Heater	Universal key
4.3 inch LCD color screen intelligent instrument	Standard fork	Front/Overhead /Rear windshield	Synchronized steering
Operator-presence control system (OPS)	Integrated electric box	Lifting valve stem horn button	Rear view camera
Flickering warning light	Overhead quard rain cover	Fire extinguisher	Tachograph
USB interface	Wide view mast	Fan	Red/blue warning light
Comfortable seat	Durable tread tyre	Double air cleaner	Finger tip operation system
Chassis protective base plate	Tilt oil circuit self lock valve	Fork extension	Overspeed alarm
Protection net of exhaust	Flow regulator	Solid tyre	Speed limit function
Adjustable steering wheel	Traction pin	Widen fork arm carrier	Starting through card or face recognition
Control valve	Starting through card (National IV model)	Cleansing muffler(certain type)	Internet of vehicle
Low exhaust	Visualized reminder for electrical appliances	Rear working light	HELI active stability safety control system (HLASS)
Back view mirror	Oil filler cap with lock	Optional attachments	HELI intelligent Anti-collision warning system(HLACW)
Handle ball steering wheel	Reversing handle(with horn)	Lifting slings	HELI visual warning system(HLWVS)
Protection for steering cylinder		Main switch	HELI smart fleet management system
Front combined lamp		High exhaust/Middle exhaust	Weighing system
Rear combined lamp		Warning light	

CPCD 20/25/30/35
CP(Q)(Y)D 20/25/30/35

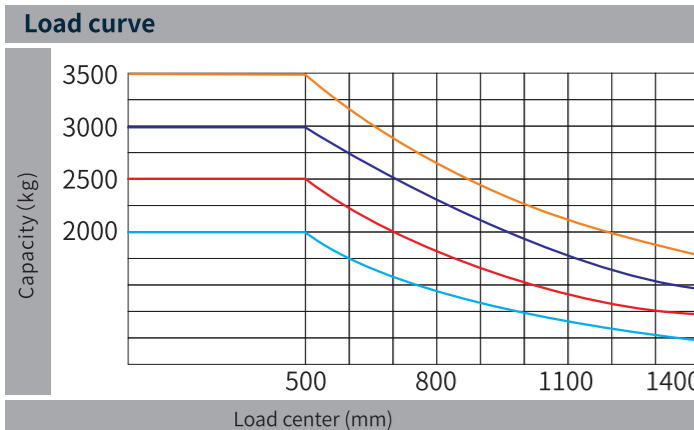

— CPCD20 — CPCD25 — CPCD30 — CPCD35
— CP(Q)(Y)D20 — CP(Q)(Y)D25 — CP(Q)(Y)D30 — CP(Q)(Y)D35

Note: The vertical axis stands for load capacity and the horizontal axis stands for load center which is calculated from the front of the fork. The base point of the standard load refers to the center position of the cube with 1000mm length of side. When mast is tilted forward, nonstandard fork usage or load with over wide goods, load capacity will be reduced. Different load capacity in different load center can be known in time through load chart.



2-3.5 t

G3 series Internal Combustion Counterbalanced Forklift Truck



ANHUI HELI CO., LTD.

Add / No.668, FangXing Road, Hefei, China

Fax / +86-551-63639966

Tel / +86-551-63639068(America); 63639258(Europe); 63639358(Asia); 63662105(Africa & Middle East)



LinkedIn



YouTube



Facebook



*New flagship of internal combustion trucks
shapes an intelligent future*

Safe / Efficient / Intelligent / Energy Saving / Comfortable

Excellent safety

The mast is equipped with overlapping pulley groups for a wide field of vision and safer operation.



The overall stamping design of the cab offers enhanced safety protection.



The controller has passed dual certifications of functional safety and CE, utilizing a dual CPU design for dual protection, further enhancing the safety of the entire truck. (Standard on trucks meeting Euro V, optional on other models)



The multi-point horn button is equipped to provide safety warnings under various conditions.

The multi-point horn button is equipped to provide safety warnings under various conditions. **Driver Presence Safety System**

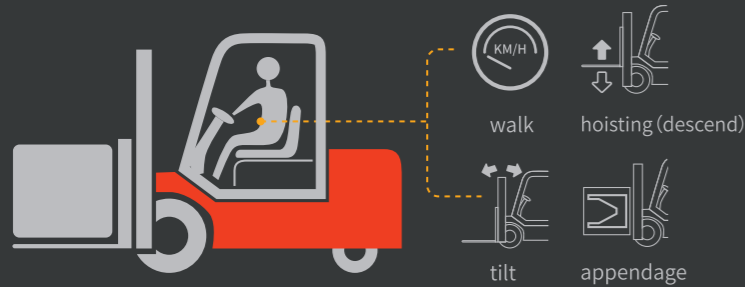

The driver presence safety system meets the needs of different regional customers, making driving operations safer.



Personalized speed control system meets different speed limit requirements (electronic control machine).

Significant Efficiency

- The truck is configured with a large-capacity air filter with a safety filter and pressure alarm function to effectively purify the intake air and monitor the degree of air filter blockage in real time.
- The lifting system has been comprehensively upgraded for longer maintenance cycles and high load bearing capacity.
- The entire truck adopts a fully hydraulic load-sensitive system for precise operation, greater efficiency, and enhanced comfort.
- The truck is equipped with an electrical failure visualization warning system, which provides engine fault warnings, fault displays for the truck's electrical system, and machine maintenance information reminders for efficient and convenient operation.
- A multi-dimensional human-machine interaction intelligent instrument monitors the overall status of the truck, and can achieve functions such as card-based start-up, providing efficient and flexible operation.
- The engine hood has a large opening angle, and the front and rear bottom boards are detachable for convenient maintenance.
- Card swipe for truck start
- Password start
- Large opening angle engine cover



Starting through card



Starting through password

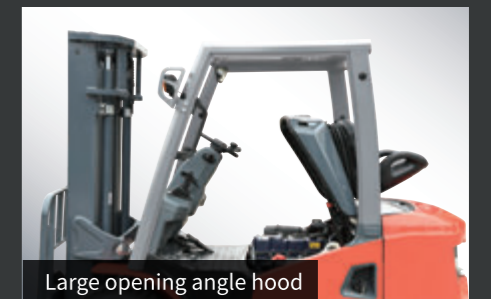

Large opening angle hood

Multi-dimensional intelligence

[HELI Active Stability System] (HLASS) (optional)

Equipped with the HELI active stability safety control system, it achieves multi safety controls such as thumb switch control, synchronized steering, automatic leveling of forks, inclined buffering at the end of forks, and mast tilting speed control, comprehensively enhancing driving and handling safety.



Mast speed control function: When working at a high position, the mast's rear tilt speed is intelligently controlled, and the front and rear tilt ends are intelligently buffered to maintain stability during high-altitude operations.

Mast angle limit function: When working at a high position, the mast's forward tilt angle is limited to maintain stability during high-altitude operations.

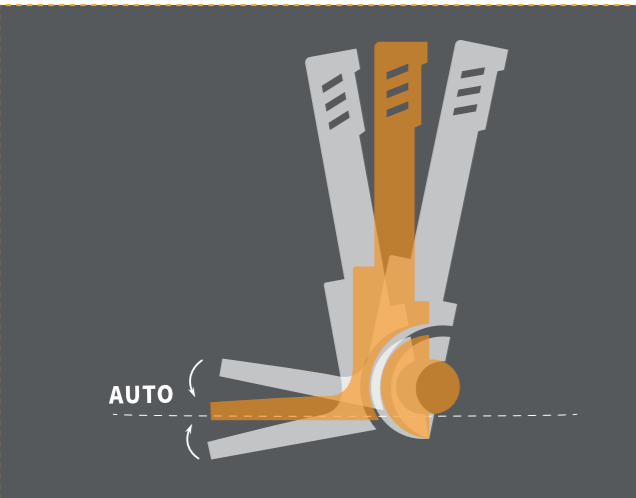

Fork one-button leveling function
When the mast is tilt, press the automatic leveling button, and the fork automatically returns to the horizontal position, which is intelligent and convenient.



Seat fingertip control
The multifunctional armrest of the seat allows you to use your fingertips to control the truck's driving, cargo loading and unloading, and warning operations.

[Synchronous steering] (optional)

The synchronous steering function: a hydraulic synchronized steering system that adjusts the steering wheel and wheel angles in real-time provides precise steering and comfortable driving.

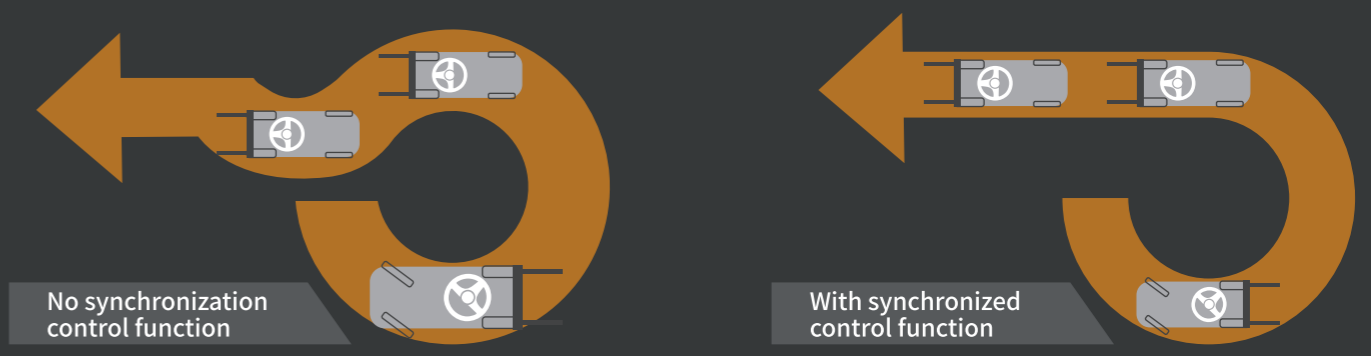

[HELI intelligent Anti-collision warning system HLACW](optional)

HELI Anti-collision Intelligent Warning System offers multiple intelligent systems such as UWB anti-collision warning and reverse anti-magnetic collision warning, providing comprehensive protection for driving safety.

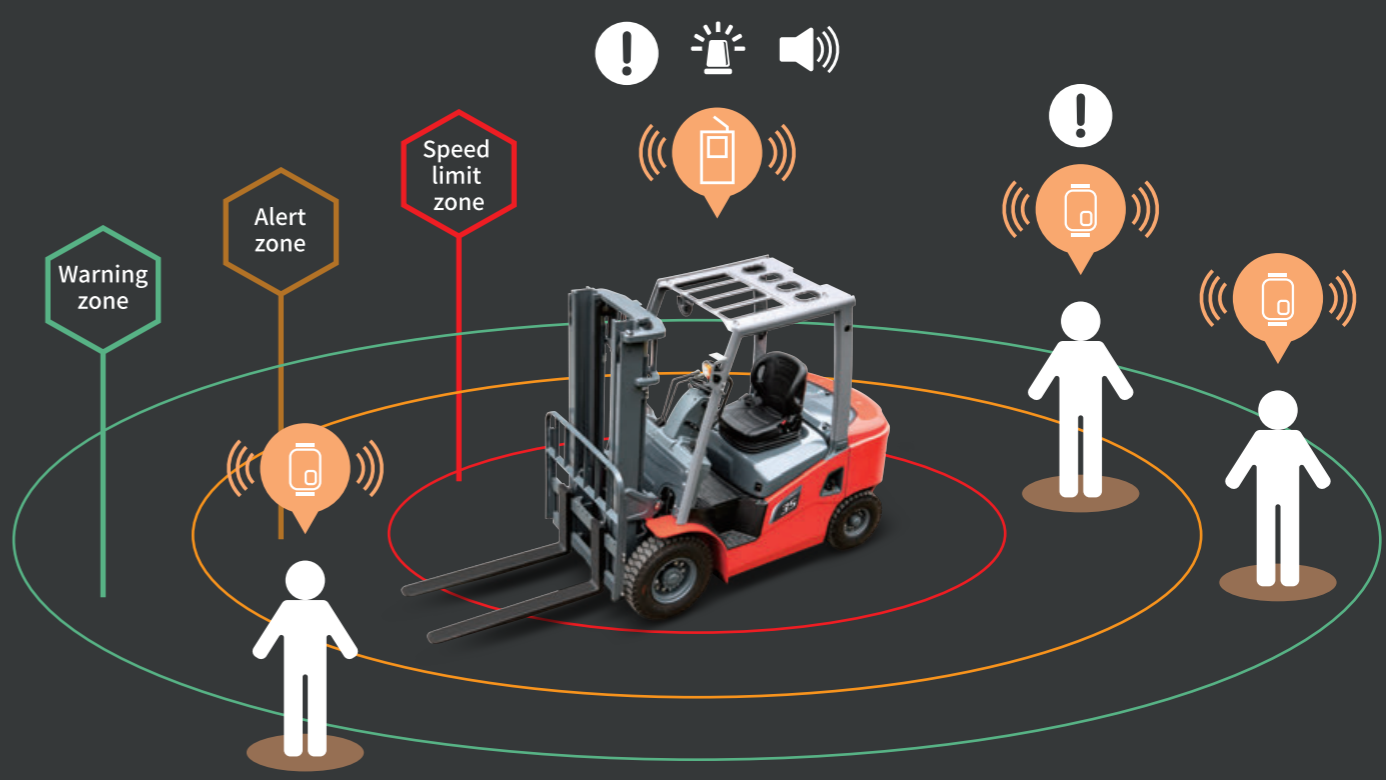

[HELI visual warning system] HLWVS (optional)

Face recognition for truck start + driver behavior recording function (Face ID + DMS)

Face recognition for truck start + driver behavior recording function + blind spot detection + truck control system + driving recording function (Face ID + DMS + BSD)

Face recognition for truck start + driver behavior recording function + 360 panorama + truck control system + driving recording function (Face ID + DMS + AVM)

Face ID: Driver identification system for truck start, ensuring exclusive use and enhancing management.

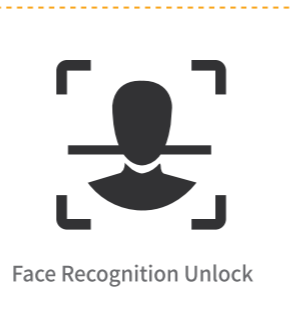

DMS: Driver Behavior Monitoring safety module improves driving safety.



Recognition and Alert for Fatigue Driving



Recognition and Alert for Phone Calls during operation



Recognition and Alert for Smoking during operation

BSD: Blind Spot Detection System to detect pedestrians approaching the truck's blind spots and display them on the screen, as well as timely alert the driver and the approaching target.

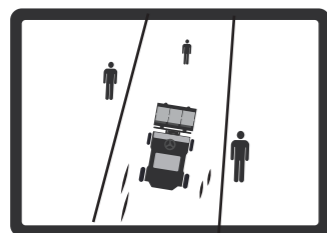

Detection of pedestrians approaching the truck's blind spots.

AVM: The 360-degree panoramic surround view system installs fisheye cameras around the truck to display the surrounding environment, and issues timely alerts.



Display and Alert of pedestrians or motor approaching.

Green and Energy-saving

- The overall truck system has been matched and upgraded, reducing the energy consumption of the entire machine by more than 15% compared to previous generation products.
- The truck is equipped with a low-loss and low-consumption hydraulic system, the hydraulic oil temperature of the entire machine is reduced by more than 20% compared to previous generation products.
- The truck is equipped with the latest emissions-compliant energy-saving internal combustion engines that meet local requirements, ensuring green and energy-saving operation.



Reduced overall truck energy consumption by more than **15%**



Hydraulic oil temperature drop of more than **20%**

Driving comfort

dB ↓

Multiple systems have been jointly upgraded, resulting in better noise performance of the entire truck.

Mast descent cushioning

The lifting system has been buffered and upgraded to reduce operational impact, providing a comfortable and safe experience.

Suspension transmission system

A small diameter steering wheel

Wet brake (optional)

Automotive integrated handles

A low steering effort steering system with a **30%** reduction in steering effort provides more efficient and comfortable steering operation.

Ultra-wide legroom

MANUFACTURER AND TECHNICAL DATA

Identification							
1.01	Manufacturer	HELI					
1.02	Model	CPCD20/CP(Q)(Y)D20	CPCD25/CP(Q)(Y)D25	CPCD30/CP(Q)(Y)D30	CPCD35/CP(Q)(Y)D35		
1.03	Drive	Diesel/ (GAS) LPG					
1.04	Operator type	Seat-type					
1.05	Rated capacity/rated load	Q	kg	2000	2500	3000	3500
1.06	Load centre distance	c	mm	500	500	500	500
1.07	Load distance, centre of drive axle to fork	x	mm	462	462	477	482
1.08	Wheelbase	y	mm	1720	1720	1770	1770
Weights							
2.01	Service weight		kg	3475	3925	4375	4720
2.02	Axle loading, laden front/rear		kg	4815/660	5655/770	6490/885	7235/985
2.03	Axle loading, unladen front/rear		kg	1275/2200	1425/2500	1575/2800	1700/3020
Wheels / chassis							
3.01	Tyres: solid rubber, superelastic, pneumatic, polyurethane	Pneumatic tire					
3.02	Tyre size, front			7.00-12-12PR	7.00-12-12PR	28*9-15-14PR	28*9-15-14PR
3.03	Tyre size, rear			6.00-9-10PR	6.00-9-10PR	6.50-10-10PR	6.50-10-10PR
3.04	Wheels, number front/rear (x = driven wheels)			2x/2	2x/2	2x/2	2x/2
3.05	Tread, front	b10	mm	970	970	1000	1000
3.06	Tread, rear	b11	mm	970	970	970	970
Dimensions							
4.01	Tilt of mast/fork carriage forward/backward	α/β	°	6/12	6/12	6/12	6/12
4.02	Height, mast lowered	h1	mm	2000	2000	2070	2120
4.03	Free lift	h2	mm	150	150	155	160
4.04	Lift	h3	mm	3000	3000	3000	3000
4.05	Height, mast extended	h4	mm	4030	4030	4217	4217
4.06	Height of overhead guard	h6	mm	2160	2160	2180	2180
4.07	Seat height/stand height	h7	mm	1030	1030	1125	1125
4.08	Coupling height	h10	mm	275	275	295	295
4.09	Overall length	l1	mm	3510	3745	3870	3895
4.10	Length to face of forks	l2	mm	2590	2675	2800	2825
4.11	Overall width	b1	mm	1160	1160	1225	1225
4.12	Fork dimensions ISO 2331	s/e/l	mm	40/122/920	40/122/1070	45/125/1070	50/125/1070
4.13	Fork carriage ISO 2328, class/type A, B			IIA	IIA	IIIA	IIIA
4.14	Fork-carriage width	b3	mm	1038	1038	1100	1100
4.15	Ground clearance, laden, below mast	m1	mm	115	115	135	135
4.16	Ground clearance, centre of wheelbase	m2	mm	125	125	145	145
4.17	Aisle width for pallets 1000 × 1200 crossways	Ast	mm	3880	3960	4070	4150
4.18	Aisle width for pallets 800 × 1200 crossways	Ast	mm	4080	4160	4270	4350
4.19	Turning radius	Wa	mm	2220	2300	2400	2475
Others							
5.01	Operating pressure for attachments		bar	140	140	140	140
5.02	Oil volume for attachments		L/min	55	55	64	64

TECHNICAL DATA

1.01	Model		CPCD20	CPCD25	CPCD30	CPCD35	CP(Q)YD20	CP(Q)YD25	CP(Q)YD30	CP(Q)YD35	
1.02	Travel speed, laden/unladen	km/h	17/18	17/18	18/19	18/19	17/18	17/18	18/19	18/19	
1.03	Lift speed, laden/unladen	m/s	0.55/0.61	0.55/0.61	0.47/0.51	0.42/0.45	0.55/0.61	0.55/0.61	0.46/0.50	0.42/0.45	
1.4	Lowering speed, laden/unladen	m/s	0.45/0.50	0.45/0.50	0.45/0.50	0.45/0.50	0.45/0.50	0.45/0.50	0.45/0.50	0.45/0.50	
1.05	Max. drawbar pull, laden/unladen	kN	22/13	22/14	21/15	20/16	24/13	24/14	23/15	22/16	
1.06	Max. gradeability, laden/unladen1	%	38/28	35/23	28/22	25/22	30/26	29/22	28/22	18/21	
1.07	Service brake		Hydraulic				Hydraulic				
Combustion engine											
2.01	Engine manufacturer/type		Quanchai 498 (China stage IV)				KUBOTA WG2503 (EU Stage V/EPA/CARB Tier3)				
2.02	Fuel type		Diesel				LPG/Gas				
2.03	Engine power according to DIN ISO 1585	kW	36.8				LPG:43.5/GAS:42.8				
2.04	Rated speed	min-1	2500				2600				
2.05	Number of cylinders/displacement	(-)/L	4/3.17				4/2.491				
2.06	Configuration model		CPCD20~35-Q29RG3				CP(Q)YD20~35-KU1RG3				

ENGINE MODEL AND MAIN SPECIFICATION OPTION

Engine Model	Rated Power/ Rotating Speed (kW/rpm)	Rated Torque/ Rotating Speed (Nm/rpm)	Engine Displacement (L)	Engine Cylinder Number-Borexstroke	Fuel Type	Emission	Truck Model
GCT GK25	LPG: 47/2600 GAS: 44/2600	LPG: 190/1600 GAS: 168/1600	2.488	4-89x100	Gas/LPG	-	CP(Q)(Y)D20-35-RC6RG3
Cummins F2.8CS449	36/2500	186/1500	2.776	4-94x100	Diesel	China Stage IV	CPCD20~35-CU6RG3
KUBOTA V2403	42.6 / 2400	195.6 / 1500	2.434	4-87 × 102.4	Diesel	Euro Stage V /EPA T4F	CPCD20~35-KU24RG3
Mitsubishi S4S	35.3/2250	177/1700	3.331	4-94 × 120	Diesel	-	CPCD20~35-M3RG3
XINCHAI 3E22YG51	44.8/2400	210/1600-1800	2.23	3-94 × 107	Diesel	Euro Stage V	CPCD20~35-XC26RG3

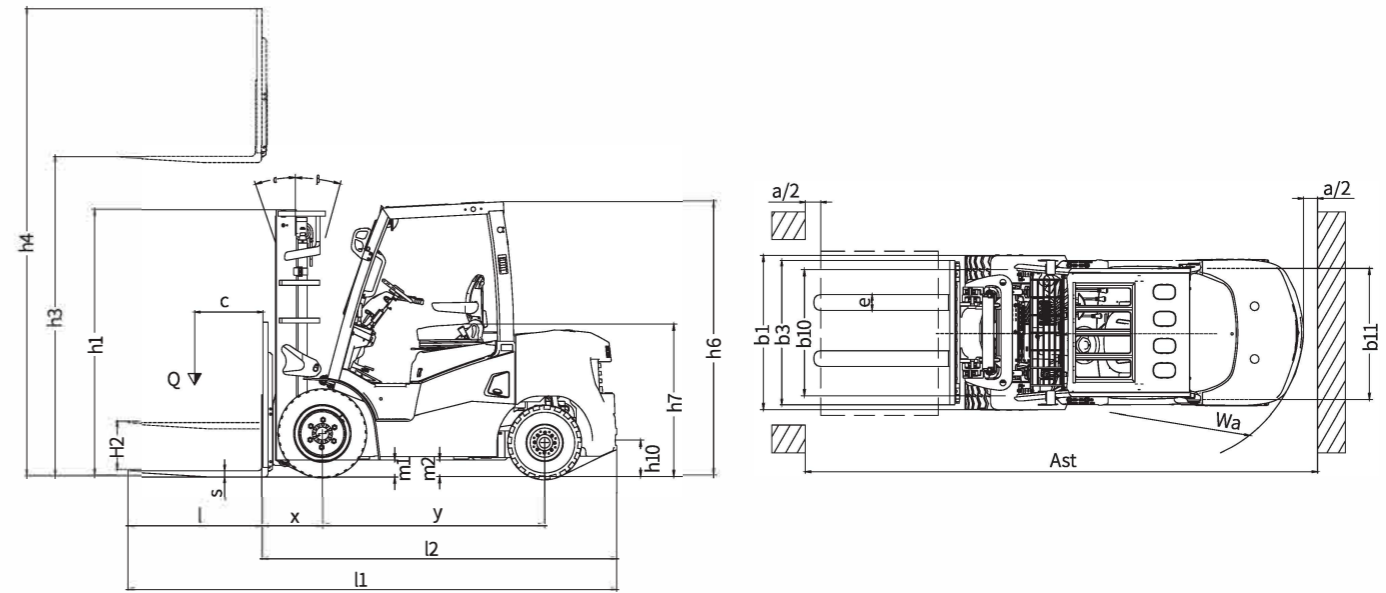

WIDE VIEW MAST

Mast model	Max. lifting height (mm)	Load capacity (loder center 500mm) (kg)				Mast height (mm)			Mast tilt angle Front/Rear	Service weight (kg)			
		2t	2.5t	3t	3.5t	2-2.5t	3t	3.5t		2t	2.5t	3t	3.5t
M300	3000	2000 2000*	2500 2500*	3000 3000*	3500 3500*	2000	2070	2120	6-12	3475	3925	4375	4720
M330	3300	2000 2000*	2500 2500*	3000 3000*	3500 3500*	2150	2220	2270	6-12	3500	3950	4400	4750
M350	3500	2000 2000*	2500 2500*	3000 3000*	3500 3500*	2250	2320	2370	6-12	3520	3970	4420	4770
M370	3700	2000 2000*	2500 2500*	3000 3000*	3500 3500*	2350	2420	2470	6-12	3535	3985	4435	4790
M400	4000	2000 2000*	2500 2500*	3000 3000*	3500 3500*	2550	2620	2670	6-12	3610	4060	4510	4865
M450	4500	1950 2000*	2300 2450*	3000 3000*	3500 3500*	2800	2870	2920	6-6 *6-6	3650	4100	4555	4910
M500	5000	1800 1950*	1850 2400*	2700 3000*	3300 3400*	3050	3120	3170	6-6 *6-6	3695	4145	4600	4960
M550	5500	1850*	2300*	2750*	2950*	3350	3420	3470	*3-6	3785	4235	4690	5055
M600	6000	1650*	1850*	2250*	2450*	3600	3670	3720	*3-6	3830	4280	4740	5105

Note: ① * stands for rated capacity for trucks with dual front tyre; ② When trucks with dual front tyre, the service weight is the data in the table plus 110kg.

WIDE VIEW FULL FREE 2-STAGE MAST

Mast model	Max. lifting height (mm)	Load capacity (loder center 500mm) (kg)				Mast height (mm)			Free lift (with backrest) (mm)			Mast tilt angle Front/Rear	Service weight (kg)			
		2t	2.5t	3t	3.5t	2-2.5t	3t	3.5t	2-2.5t	3t	3.5t		2t	2.5t	3t	3.5t
ZM300	3000	2000 2000*	2500 2500*	3000 3000*	3500 3500*	2000	2070	2120	991	888	943	6-12	3505	3950	4470	4790
ZM330	3300	2000 2000*	2500 2500*	3000 3000*	3500 3500*	2150	2220	2270	1141	1038	1093	6-12	3535	3980	4500	4825
ZM350	3500	2000 2000*	2500 2500*	3000 3000*	3500 3500*	2250	2320	2370	1241	1138	1193	6-12	3550	4000	4520	4845
ZM370	3700	2000 2000*	2500 2500*	3000 3000*	3500 3500*	2350	2420	2470	1341	1238	1293	6-12	3570	4020	4540	4865
ZM400	4000	2000 2000*	2500 2500*	3000 3000*	3500 3500*	2550	2620	2670	1541	1438	1493	6-12	3650	4100	4620	4945

Note: ① * stands for rated capacity for trucks with dual front tyre; ② When trucks with dual front tyre, the service weight is the data in the table plus 110kg.

WIDE VIEW FULL FREE 3-STAGE MAST

Mast model	Max. lifting height (mm)	Load capacity (loder center 500mm) (kg)				Mast height (mm)			Free lift (with backrest) (mm)			Mast tilt angle Front/Rear	Service weight (kg)			
		2t	2.5t	3t	3.5t	2-2.5t	3t	3.5t	2-2.5t	3t	3.5t		2t	2.5t	3t	3.5t
ZSM435	4350	2000 2000*	2500 2500*	3000 3000*	3500 3500*	2050	2120	2120	1041	938	943	6-6	3685	4135	4600	4910
ZSM450	4500	2000 2000*	2500 2500*	3000 3000*	3500 3500*	2100	2170	2170	1091	988	993	6-6	3700	4150	4615	4925
ZSM470	4700	1900 2000*	2200 2500*	2900 3000*	3400 3500*	2165	2230	2230	1156	1048	1053	6-6 *6-6	3720	4170	4630	4940
ZSM500	5000	1700 2000*	1750 2400*	2700 2950*	3100 3300*	2300	2370	2370	1291	1188	1193	6-6 *6-6	3750	4200	4660	4980
ZSM540	5400	1450 1900*	1500 2200*	2300 2800*	2650 3150*	2400	2470	2470	1391	1288	1293	6-6 *6-6	3780	4230	4700	5005
ZSM600	6000	950 1650*	1000 1800*	1550 2150*	1900 2450*	2600	2670	2670	1591	1488	1493	6-6 *6-6	3880	4330	4790	5105
ZSM650	6500	1600*	1650*	1800*	2000*	2800	2870	2870	1795	1688	1693	*3-3	3940	4390	4850	5160
ZSM700	7000	1250*	1300*	1400*	1500*	2975	3045	3045	1966	1863	1868	*3-3	3985	4435	4890	5205

Note: ① * stands for rated capacity for trucks with dual front tyre; ② When trucks with dual front tyre, the service weight is the data in the table plus 110kg.