

# LGMG

## H625

### TELEHANDLER

**6m**

WORKING HEIGHT

**2500kg**

RATED LOAD



# LGMG TELEHANDLER

## SPECIFICATIONS

MODELS	H625	
Measurements	Metric	Imperial
<b>A</b> Max. Lifting Height	5.94m	19'6"
Max. Outreach	3.41m	11'2"
<b>B</b> Overall Length	3.99m	13'1"
<b>C</b> Overall Width	1.86m	6'1"
<b>D</b> Overall Height	1.97m	6'6"
<b>E</b> Wheelbase	2.3m	7'7"
Ground Clearance	0.32m	1'1"
<b>PRODUCTIVITY</b>		
Max. Capacity	2,500kg	5512 lbs
Gradeability-Unladen	45%	
Min. Turning Radius	3.36m	11'
Tilt Angle	±5°	
Drive /Steering Mode	4 Wheel Drive / 4 Wheel Steer	
Primary Boom Ascending Time	9s	
Primary Boom Descending Time	6.5s	
Boom Extending Time	6s	
Boom Retracting Time	4s	
Forward - First Gear Travel Speed	10km/h	6.2mph
Forward - Second Gear Travel Speed	24.9km/h	15.5mph
Backward - First Gear Travel Speed	10km/h	6.2mph
Backward - Second Gear Travel Speed	24.9km/h	15.5mph
Service brake	Multi-disc wet brake of front axle	
Standard Tyres	12-16.5-12-TL	
<b>ENGINE</b>		
Manufacturer	Kubota	
Rated Power	54.6kW	73.2hp
Max. Torque	289.3N.m	213.4 lb.ft
Displacement	3,331ml	203.3 cu.in
Fuel Tank Capacity	63L	16.6 gal
Maximum traction force	39kN	
<b>HYDRAULIC SYSTEM</b>		
Working pump displacement	84 l/min	22 US gpm
Hydraulic Oil Capacity	75L	19.8 gal
<b>WEIGHT</b>		
Machine Weight	5,050kg	11,134 lbs

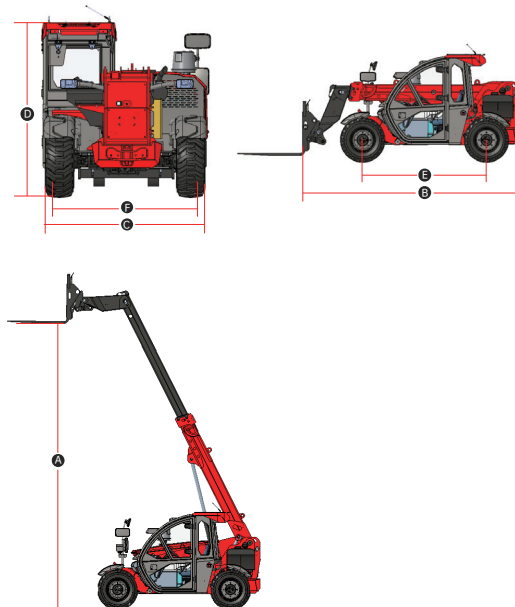

## ROUGH TERRAIN LOAD CHART

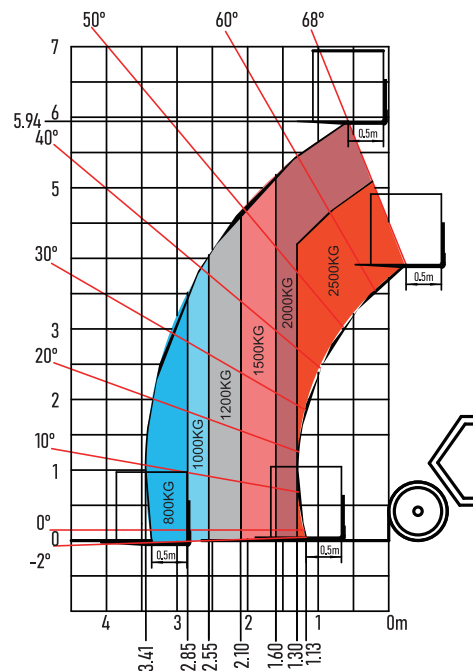

Please contact LGMG or a local dealer for more details.

LGMG reserves the right to change technical data without prior notice. All photos and pictures in this brochure are for promotional purposes only.

**LINGONG HEAVY MACHINERY CO., LTD.**

Address: No. 2676, Kejia Road, Jinan, Shandong, China

Email: sales@lmg.com.cn Tel: +86 531 6787 9283

www.lmglifts.com



RELIABILITY IN ACTION